

# PRODUCT PROFILE

## PanelView Plus & PanelView Plus CE

### Benefits

PanelView Plus is one of the most versatile operator interface options in the suite of visualization solutions. The PanelView Plus family of products provides a broad range of rugged terminals that offer:

- Seamless integration into Integrated Architecture
- Common development software for scalability
- Modularity
- Multivendor communications

### PanelView Plus CE Advantages:

- Save time by viewing manuals directly on your terminal
- Access production schedules directly from the terminal
- Save time by including training documents and video on the terminal
- Allow remote access to the terminal with VNC (Virtual Network Computing)

All this is achieved through various file viewers: Internet Explorer, Terminal Services, FTP functionality, Adobe PDF Viewer, and Microsoft Office file viewers including Word, Excel and Powerpoint.

### Optimize system design

PanelView Plus is ideal for machine level operator terminal applications in an industrial environment.

- FactoryTalk View Machine Edition comes installed and activated to provide the seamless integration into your control system, saving time and expense
- Bright displays with 18 bit color graphics work together to show the advanced functionality and pre-engineered faceplates that are built into each terminal.
- All PanelView Plus terminals are programmed utilizing a common development environment that can also program high level, multi-client, multi server supervisory applications.



### More functionality with PanelView Plus CE

Over the years, Rockwell Automation has earned a reputation for offering a wide range of visualization solutions, which include products that are scalable and available in multiple configurations, platforms and sizes. We are expanding the PanelView Plus visualization product line by adding an open Windows CE platform. The expansion of the PanelView Plus line to include PanelView Plus CE is a logical evolution for Rockwell Automation, as we add more functionality as an option to our most popular product.

### Multiple communication options

Most PanelView Plus terminals include Ethernet/IP communications as standard and all come standard with RS232 communications to work with all Allen-Bradley controllers (additional third party communications available with Kep Ware). Optional, field installable modules provide ControlNet, DeviceNet, RIO, DH+, DH485, Modbus Plus and PROFIBUS communications.

FEATURE	PanelView Plus 400-1500	PanelView Plus CE 700-1500
FactoryTalk Machine Edition	✓	✓
Data Logging	✓	✓
Trending	✓	✓
No Hard drive, fans or moving parts	✓	✓
MPEG/ JPEG Viewers		✓
Microsoft Office Viewer		✓
Active X Controls		✓
CAD Viewer		✓
Microsoft Internet Explorer		✓
Terminal Services		✓
Virtual Network Computing		✓
Active Sync		✓

## Broad product selection

The PanelView Plus family starts with 4-inch grayscale terminals with keypad input as the smallest, lowest cost option. Larger, TFT color displays up to 15-inch are available to allow more information to be seen on a single screen or allow for larger graphics. Input can optionally be the smaller, more intuitive touch screens, a keypad for increased display longevity in harsh environments, or a combination of both. This allows you to select based on your needs and budget.

## Catalog Configuration

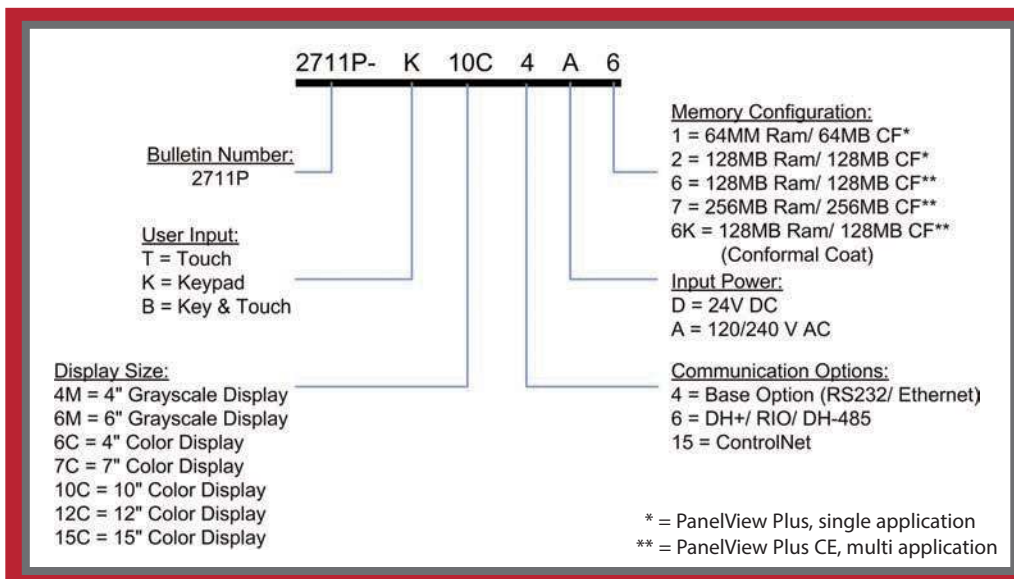

[www.rockwellautomation.com](http://www.rockwellautomation.com)

### Power, Control and Information Solutions Headquarters

Americas: Rockwell Automation, 1201 South Second Street, Milwaukee, WI 53204-2496 USA, Tel: (1) 414.382.2000, Fax: (1) 414.382.4444

Europe/Middle East/Africa: Rockwell Automation, Vorstlaan/Boulevard du Souverain 36, 1170 Brussels, Belgium, Tel: (32) 2 663 0600, Fax: (32) 2 663 0640

Asia Pacific: Rockwell Automation, Level 14, Core F, Cyberport 3, 100 Cyberport Road, Hong Kong, Tel: (852) 2887 4788, Fax: (852) 2508 1846